

OPEN 8 ECO

PARETE PRINCIPALE / MAIN WALL /
PAROI PRINCIPALE / HOOFDWAND / HAUPTWAND



H. 200cm
SP. 8mm



Parete vetro con area di accesso totalmente libera, con la sola presenza del profilo verticale e di un braccetto di sostegno a dare stabilità al prodotto

Glass wall with a completely open access area, featuring only a vertical profile and a support arm to provide stability to the product.

Paroi en verre avec zone d'accès totalement libre, avec uniquement le profil vertical et un bras de soutien pour assurer la stabilité du produit.

Glazen wand met volledig vrije toegangsruimte, met alleen het verticale profiel et een steunarm voor de stabiliteit van het product.

Glaswand mit völlig freiem Zugang, nur mit einem vertikalen Profil und einem Stützarm zur Stabilisierung des Produkts.

CONFIGURAZIONE AD ANGOLO / CORNER
CONFIGURATION / CONFIGURATION D'ANGLE /
HOEKCONFIGURATIE / ECKKONFIGURATION

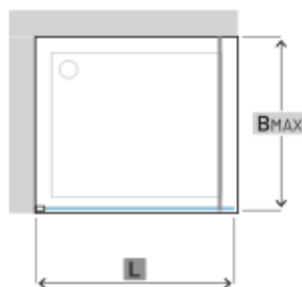

ORIENTAMENTO E POSSIBILI COMBINAZIONI / ORIENTATION AND POSSIBLE CONFIGURATIONS / ORIENTATION ET COMBINAISONS POSSIBLES /
ORIËNTATIE EN MOGELIJKE COMBINATIES / AUSRICHTUNG UND MÖGLICHE KOMBINATIONEN

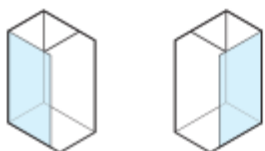

STANDARD

ULU Brillantato Lucido / Brilliant Polished
Chromé Brillant / Glanzend Gepolijst
Hochglanz Poliert

L96 Nero Opaco / Matte Black
Noir Mat / Zwart Matte
Schwarz Matt

STANDARD

TR Trasparente / Transparent
Transparent / Transparant /
Transparent

CONFIGURAZIONE AD ANGOLO / CORNER
 CONFIGURATION / CONFIGURATION D'ANGLE /
 HOEKCONFIGURATIE / ECKKONFIGURATION

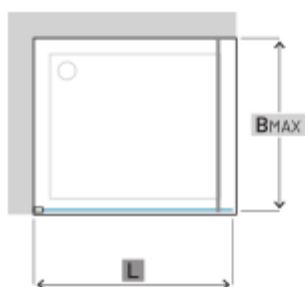

PORTA / DOOR / PORTE / DEUR / TÜR

L [cm]	COD.	B MAX [cm]	[dm ³]	[kg]	[Pcs]
78,5-80	B2340	120	100	35	1
88,5-90	B2341	120	115	39	1
198,5-100	B2342	120	130	44	1
118,2-120	B2343	120	150	51	1
138,5-140	B2344	120	180	59	1
158,5-160	B2345	120	205	67	1

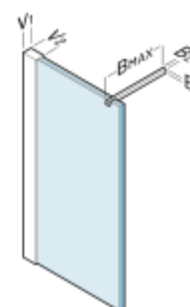

L	
V ₁	18mm
V ₂	40mm
B ₁	10mm
B ₂	30mm
B _{MAX}	120cm

B2340-2341-2342-2343-2344-2345

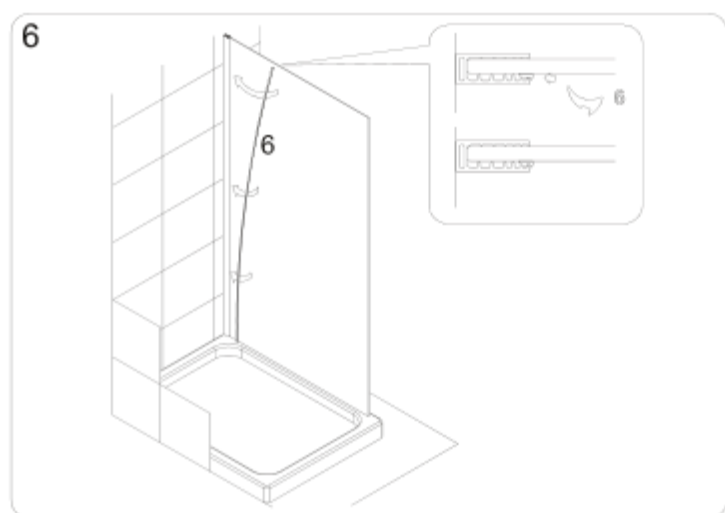
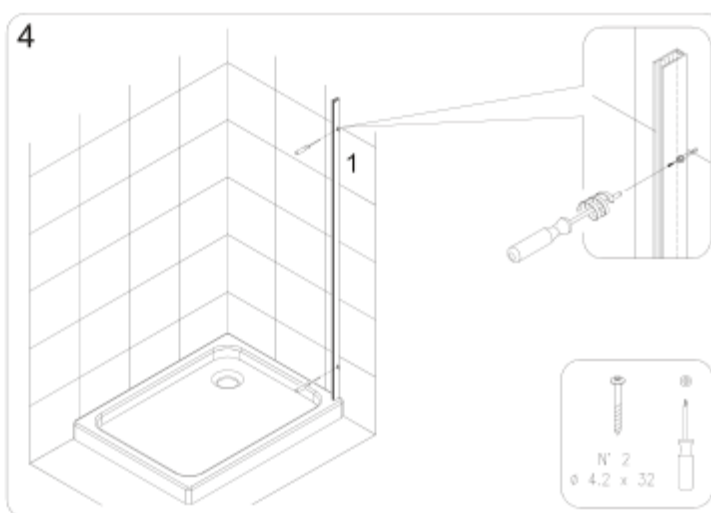
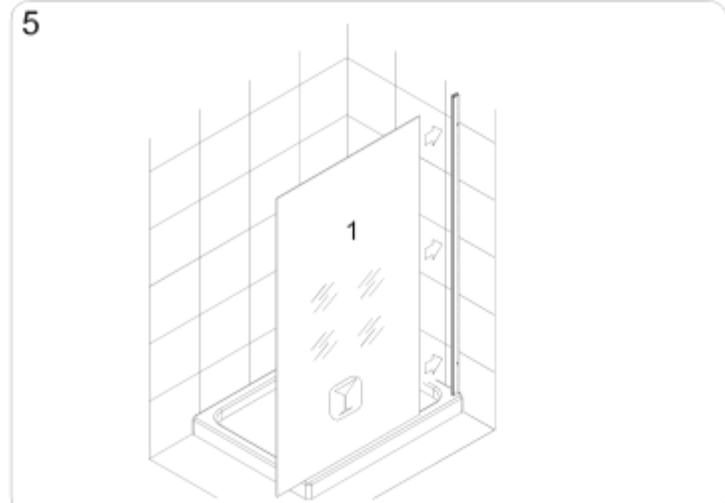
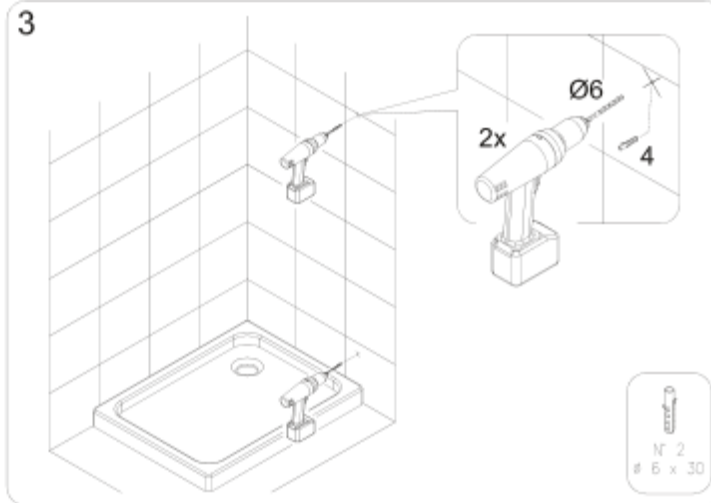
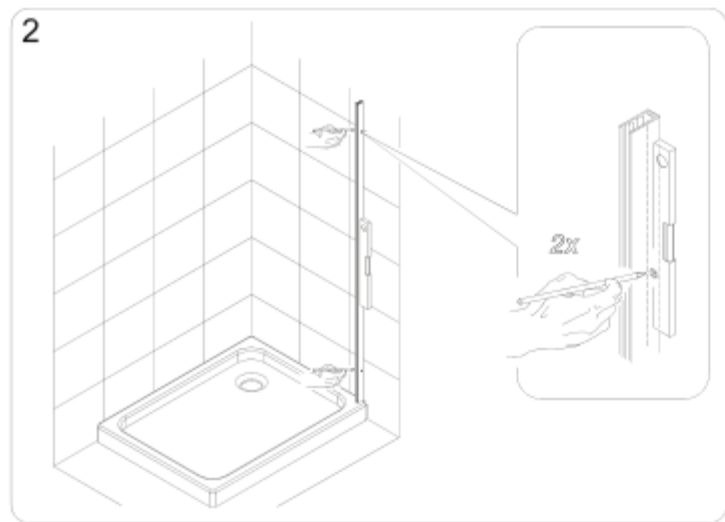
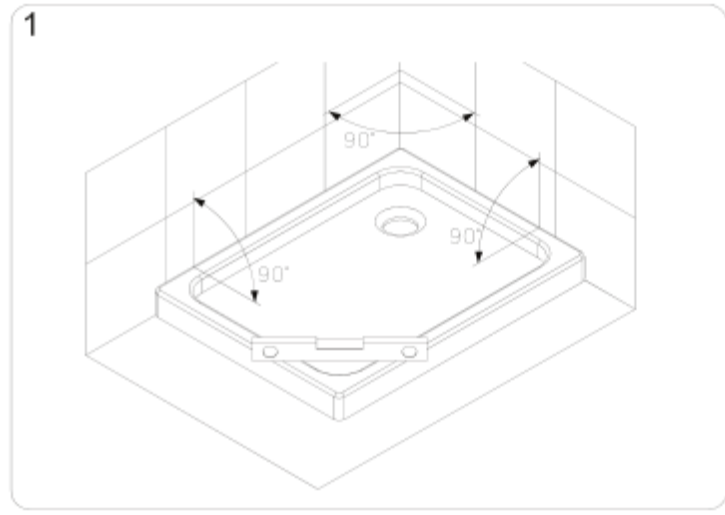
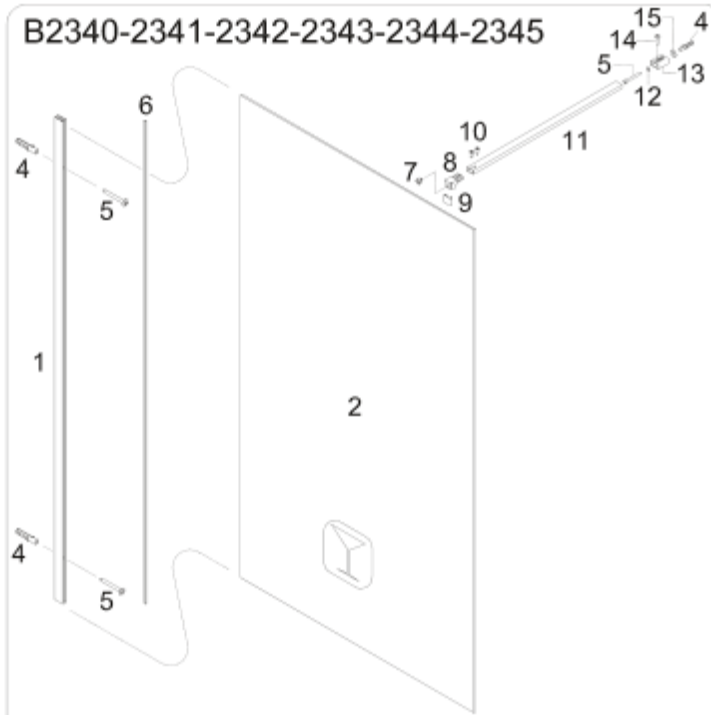

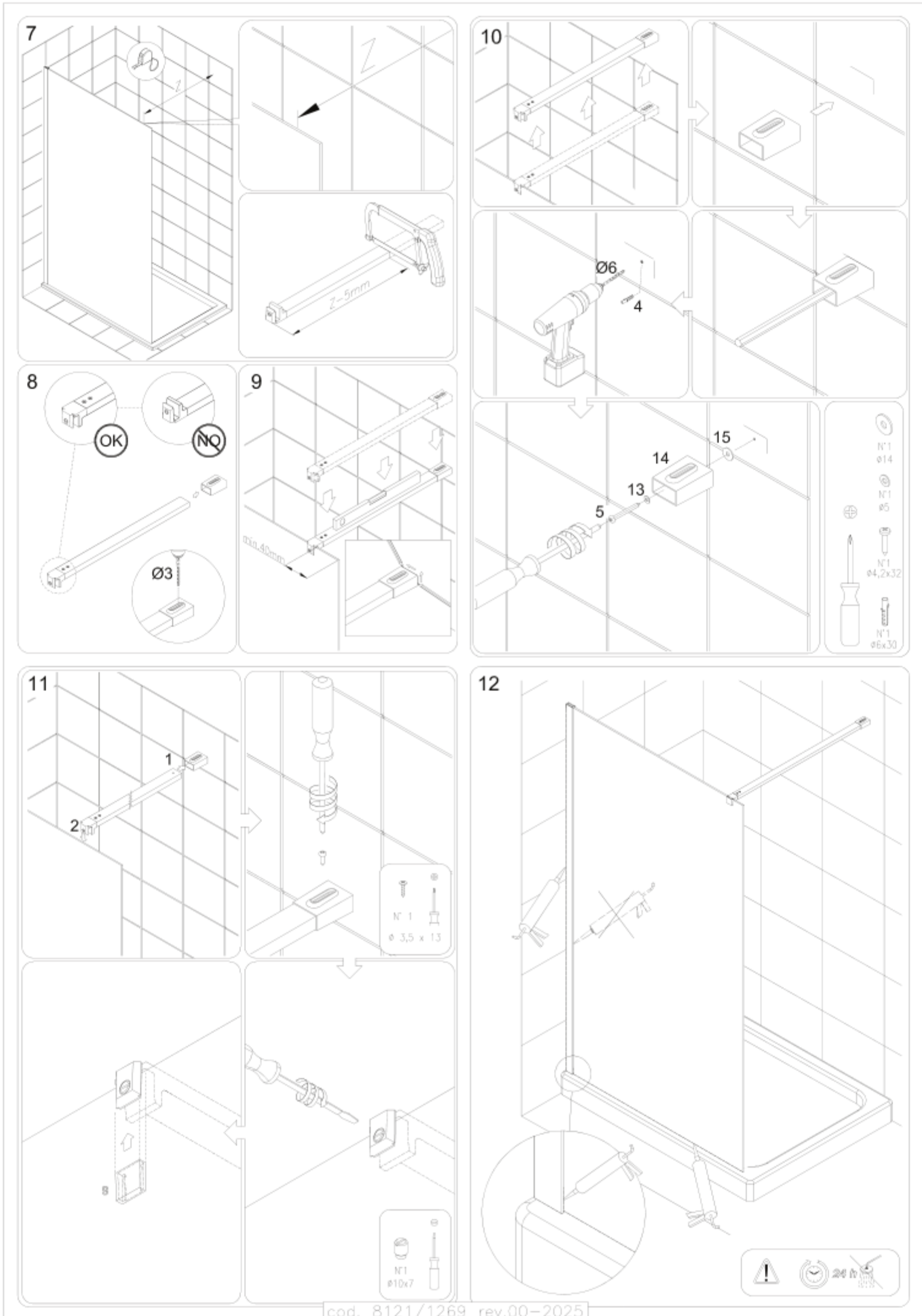

cod. 8121/1269 rev.00-2025