

35

35mm
35mm cartridge

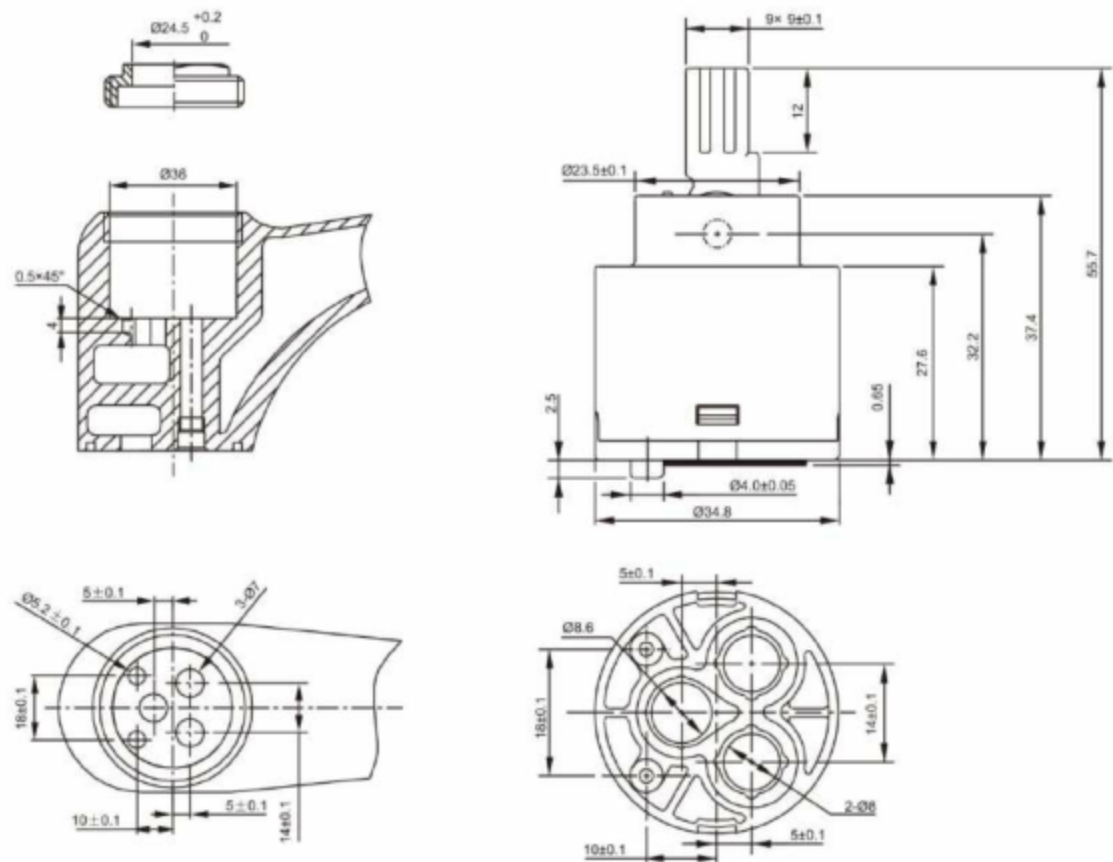

Technical draw



Technique Specification

Parameter											
Min. Opening Angle	23°				Max. Temperature				95°C		
	100°				Lever Break Torque				≥ 12N.m		
Max. Turning Angle					Gland Nut Torque				8-10N.m		
Pressure (bar)	0.5	1	1.5	2	2.5	3	3.5	4	4.5	5	
Average Flow Rate (L/min)	9.5	11.1	12.8	14.7	16.4	18	19.7	21.5	23.1	26.8	
Testing Performance											
Burst Test	Staic Water pressure at Max.35bar,no deformation found on the cartridge										
Life Test	Min.70,000 Cycles(EN 817. GB 18145)										
Ceramic Disc Data											
Sealing Surface Of Ceramic Disc	Hardness		>1000HV5				Flatness		≤ 0.3 μm		
	Surface Roughness		Ra ≤ 0.2 μm								